



## JOC815 Series

Rev.A.1.0

### DESCRIPTION:

The JOC815 series combine an AlGaAs infrared emitting diode as the emitter which is optically coupled to a silicon planar darlington phototransistor detector in a plastic DIP4 package with different lead forming options. With the robust coplanar double mold structure, JOC815 series provide the most stable isolation feature. The products are widely used in sequence controller, telephone/FAX, system appliances, measuring instrument and programmable logic controller.

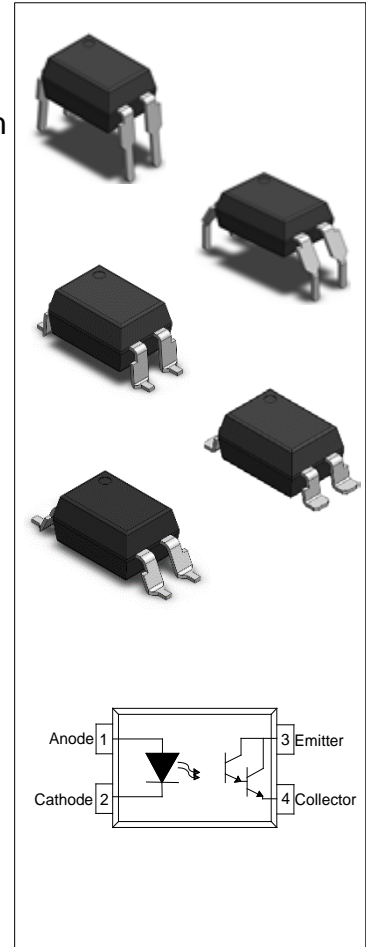

### MAIN FEATURES

Current transfer ratio (CTR: 600%-7500% @ $I_F=1\text{mA}$ ,  $V_{CE}=2\text{V}$ )

High isolation voltage between input and output

( $V_{iso}=5,000\text{Vrms}$ )

Operating temperature up to +110°C

Collector-Emitter voltage  $BV_{CEO} \geq 40\text{V}$

CQC approved

VDE approved

UL approved

The products comply with RoHS, REACH and HF

### ABSOLUTE MAXIMUM RATINGS (Temperature=25°C)

Parameter		Symbol	Value	Unit
Input	Forward Current	$I_F$	60	mA
	Peak Forward Current	$I_{FP}$	1 <sup>①</sup>	A
	Reverse Voltage	$V_R$	6	V
	Power Dissipation	$P_D$	100	mW
Output	Collector-emitter Voltage	$V_{CEO}$	40	V
	Emitter-collector Voltage	$V_{ECO}$	6	V
	Collector Current	$I_C$	80	mA
	Power Dissipation	$P_C$	150	mW
Total Power Dissipation		$P_{tot}$	250	mW

Isolation Voltage	$V_{iso}$	5000 <sup>②</sup>	Vrms
Operating Temperature	$T_{opr}$	-55~+110	°C
Storage Temperature	$T_{stg}$	-55~+125	°C
Soldering Temperature	$T_{sol}$	260	°C

**NOTE1:** 100μs pulse, 100Hz frequency

**NOTE2:** AC for 1minute, R.H.=40~60%

### ELECTRICAL CHARACTERISTICS (Temperature=25°C)

Parameter		Symbol	Condition	Min.	Typ.	Max.	Unit
Input	Forward Voltage	$V_F$	$I_F=10mA$	-	1.24	1.4	V
			$I_F=20mA$	-	1.28	1.5	
	Reverse Current	$I_R$	$V_R=6V$	-	-	1	μA
	Terminal Capacitance	$C_t$	$V=0,$ $f=1MHz$	-	30	250	pF
Output	Collector-Emitter dark current	$I_{CEO}$	$V_{CE}=10V,$ $I_F=0$	-	-	50	nA
	Collector-Emitter breakdown voltage	$BV_{CEO}$	$I_C=0.1mA$ $I_F=0$	40	-	-	V
	Emitter-Collector breakdown voltage	$BV_{ECO}$	$I_E=0.1mA$ $I_F=0$	6	-	-	V
Transfer Characteristics	Current transfer ratio	$CTR$ <sup>①</sup>	$I_F=1mA$ $V_{CE}=2V$	600	-	7500	%
	Collector-Emitter Saturation Voltage	$V_{CE(sat)}$	$I_F=20mA$ $I_C=5mA$	-	0.8	1	V
	Isolation resistance	$R_{io}$	DC500V 40~60%R.H.	$5 \times 10^{10}$	$10^{11}$	-	Ω
	Floating Capacitance	$C_{io}$	$V=0,$ $f=1MHz$	-	0.4	1	pF
	Cut-off Frequency	$f_c$	$V_{CE}=5V,$ $I_C=2mA$ $R_L=100\Omega,$ -3dB	-	6	-	kHz
	Rise Time	$t_r$	$V_{CE}=2V,$ $I_C=10mA$	-	5	18	μs
	Fall Time	$t_f$	$R_L=100\Omega$	-	4	18	μs

**ORDERING AND MARKING INFORMATION**

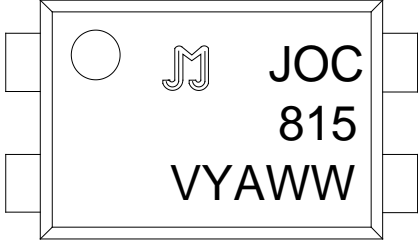
<b>MARKING INFORMATION</b>			
		<p>JOC : Company Abbr.                      815 : Part Number                      VYAWW : LOT NO.</p>	
<b>ORDERING INFORMATION</b>			
<b>JOC815(Y)(Z)-GV</b>			
<p>JOC – Company Abbr.                      815 – Part Number                      Y –Lead Form Option (M/S/SL/SLM/None)                      Z – Tape and Reel Option (T1/T2/T3/T4)                      G – Green                      V – VDE Option (V or None)</p>			
<b>Packing Quantity</b>			
Option	Quantity	Quantity – Inner box	Quantity –Outer box
None/M	100 Units/Tube	32 Tubes/Inner box	10 Inner box/Outer box =32k Units
S(T1/T2)	1500 Units/Reel	3 Reels/Inner box	5 Inner box/Outer box =22.5k Units
S(T3/T4)	1000 Units/Reel	3 Reels/Inner box	5 Inner box/Outer box =15k Units
SL(T1/T2)	1500 Units/Reel	3 Reels/Inner box	5 Inner box/Outer box =22.5k Units
SL(T3/T4)	1000 Units/Reel	3 Reels/Inner box	5 Inner box/Outer box =15k Units
SLM(T1/T2)	1000 Units/Reel	3 Reels/Inner box	5 Inner box/Outer box =15k Units

Characteristics Curves

FIG.1: Forward Current vs. Ambient Temperature

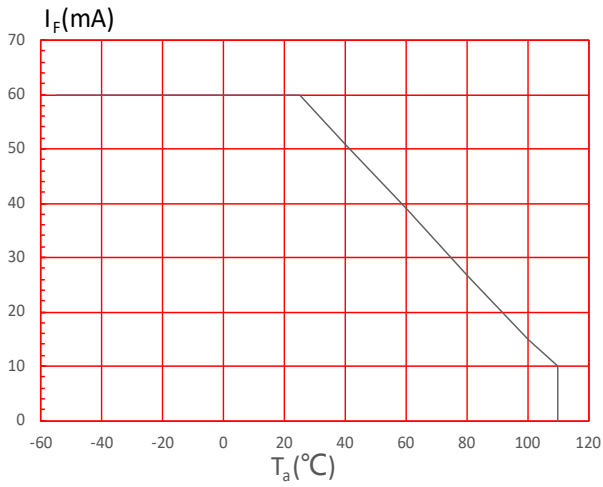

FIG.2: Collector Power Dissipation vs. Ambient Temperature

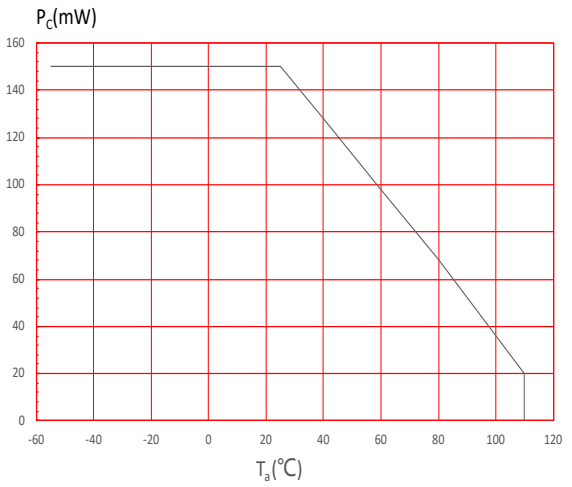

FIG.3: Forward Current vs. Forward Voltage

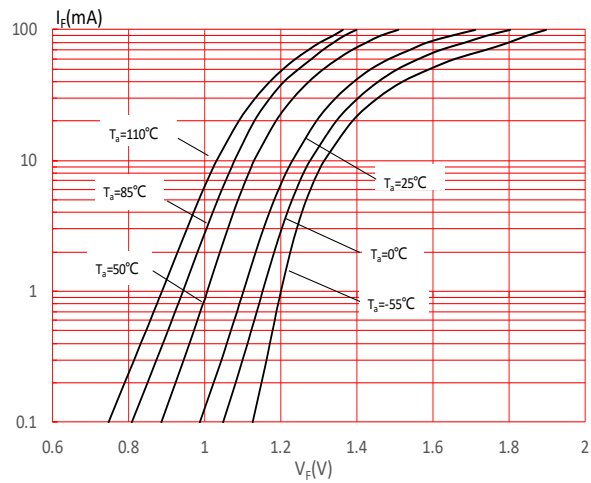

FIG.4: Normalized Collector Dark Current vs. Ambient Temperature

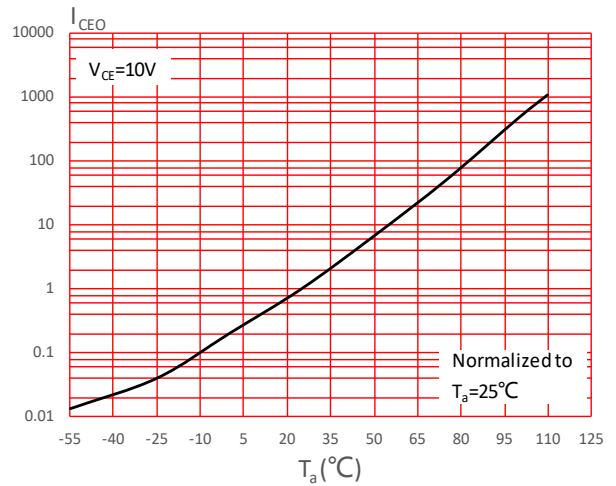

FIG.5: Collector Current vs. Collector-emitter Voltage

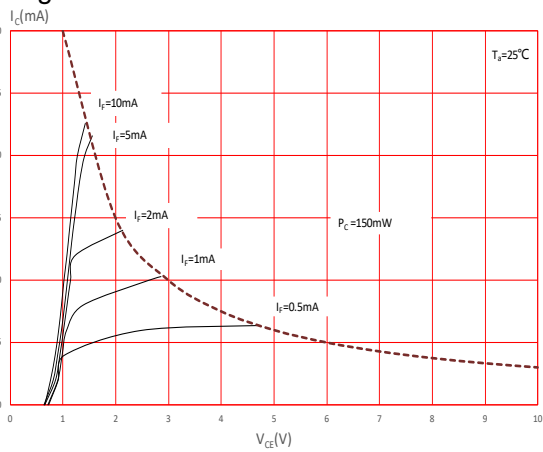
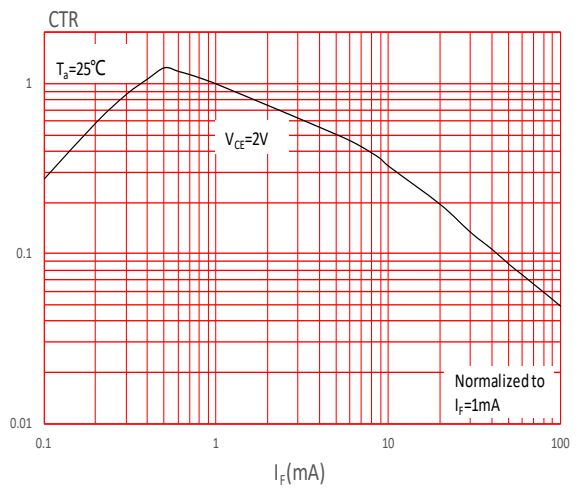
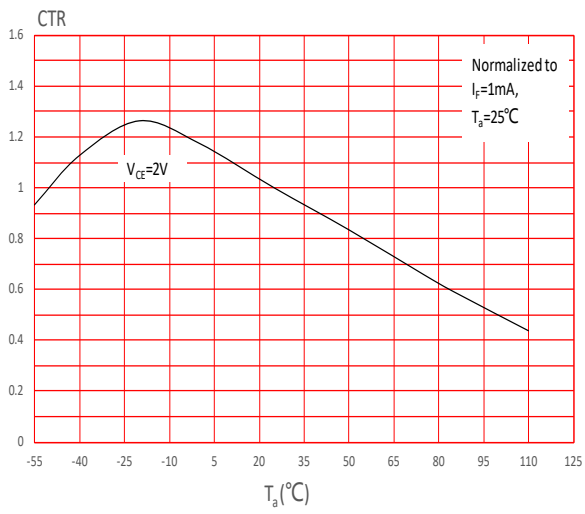

FIG.6: Normalized Current Transfer Ratio vs. Forward Current



**FIG.7:** Normalized Current Transfer Ratio vs. Ambient Temperature



**FIG.8:** Normalized Collector-emitter Saturation Voltage vs. Ambient Temperature

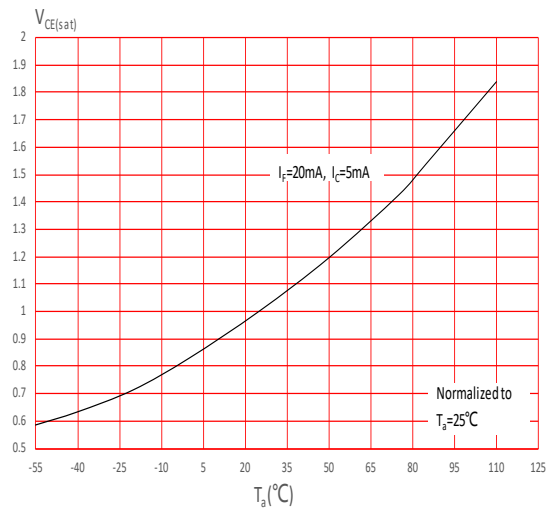

**FIG.9:** Response Time vs. Load Resistance

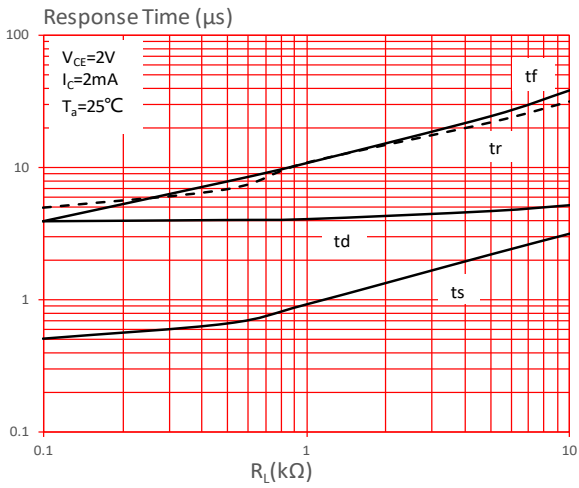

**FIG.10:** Frequency Response

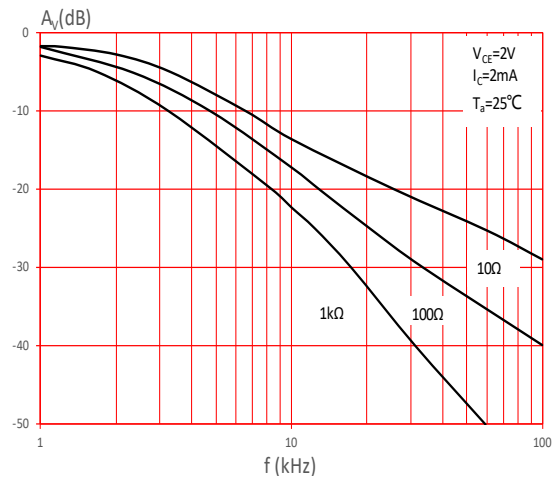

Test Circuits

FIG.11: Test Circuits of Response Time

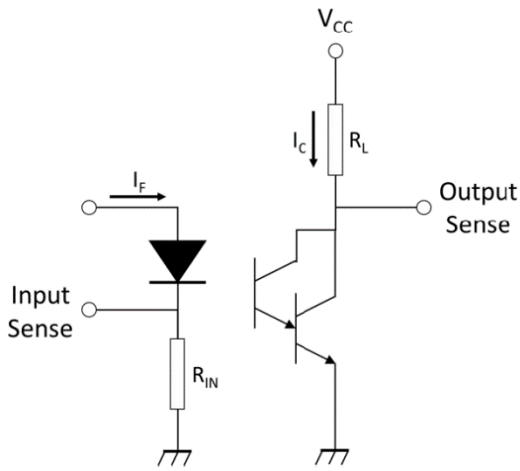

FIG.12: Curves of Response Time

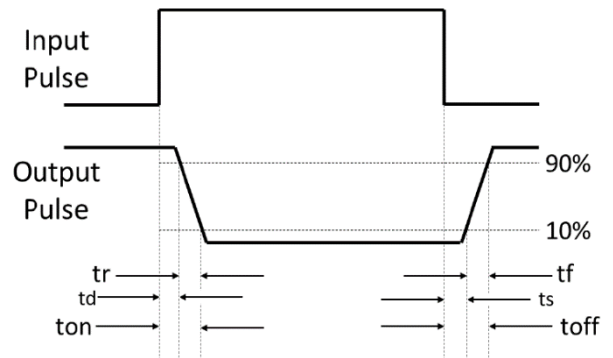
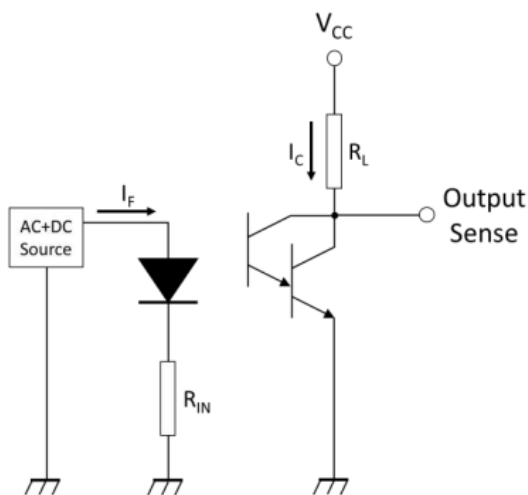
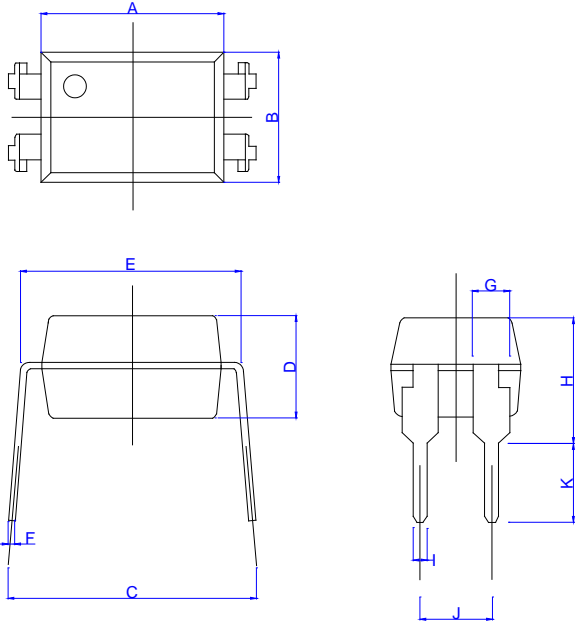

FIG.13: Test Circuits of Frequency Response



Package Dimension (Unit: mm)

Standard DIP Type:



Ref.	Dimensions					
	Millimeters			Inches		
	Min.	Typ.	Max.	Min.	Typ.	Max.
A	6.00		7.00	0.236		0.276
B	4.08		5.08	0.161		0.200
C	7.62		10.16	0.300		0.400
D	3.00		4.00	0.118		0.157
E	7.32		7.92	0.288		0.312
F	0.15		0.36	0.006		0.014
G	0.90		1.50	0.035		0.059
H	3.50		4.80	0.138		0.189
I	0.40		0.60	0.016		0.024
J	2.29		2.79	0.090		0.110
K	2.45		3.50	0.096		0.138

Option M Type:

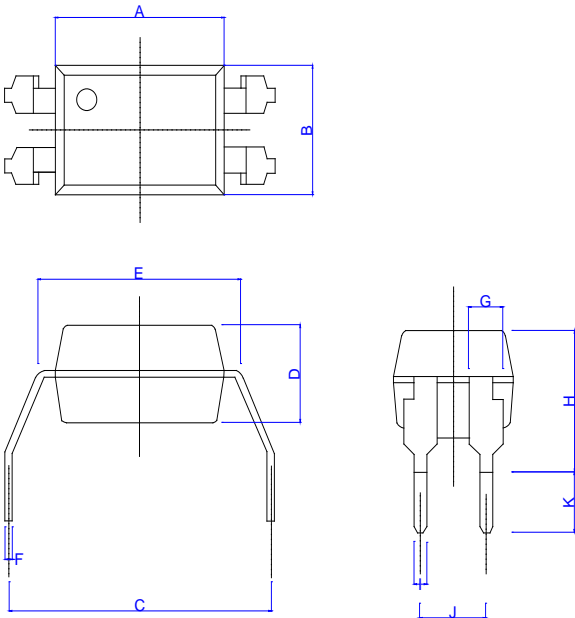

Ref.	Dimensions					
	Millimeters			Inches		
	Min.	Typ.	Max.	Min.	Typ.	Max.
A	6.20		6.80	0.244		0.268
B	4.10		4.90	0.161		0.193
C	9.66		10.66	0.380		0.420
D	3.00		4.00	0.118		0.157
E	7.32		7.92	0.288		0.312
F	0.15		0.36	0.006		0.014
G	0.90		1.50	0.036		0.059
H	4.16		4.88	0.164		0.192
I	0.40		0.60	0.016		0.024
J	2.29		2.79	0.090		0.110
K	2.00		2.70	0.079		0.106

Option S Type:

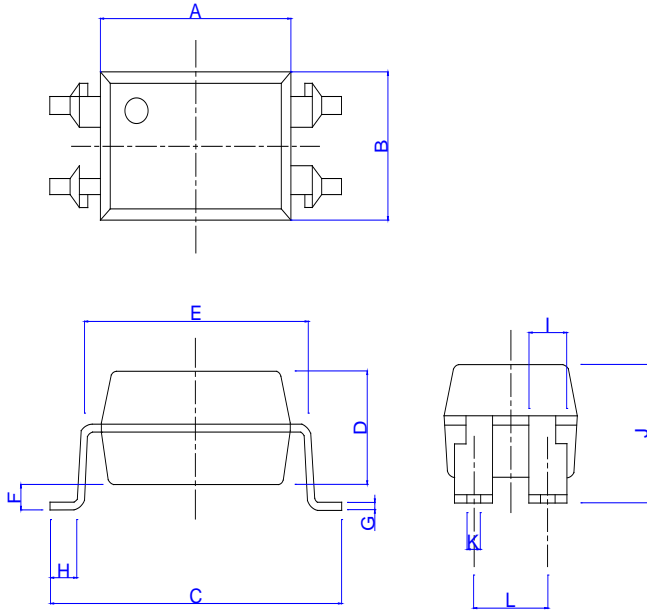

Ref.	Dimensions					
	Millimeters			Inches		
	Min.	Typ.	Max.	Min.	Typ.	Max.
A	6.20		6.80	0.244		0.268
B	4.30		4.90	0.169		0.193
C	9.86		10.50	0.388		0.413
D	3.20		3.80	0.126		0.150
E	7.32		7.92	0.288		0.312
F	0.00		1.00	0.000		0.039
G	0.15		0.35	0.006		0.014
H	0.50		1.10	0.020		0.043
I	1.10		1.50	0.043		0.059
J	3.50		4.80	0.138		0.189
K	0.40		0.60	0.016		0.024
L	2.29		2.79	0.090		0.110

Option SL Type:

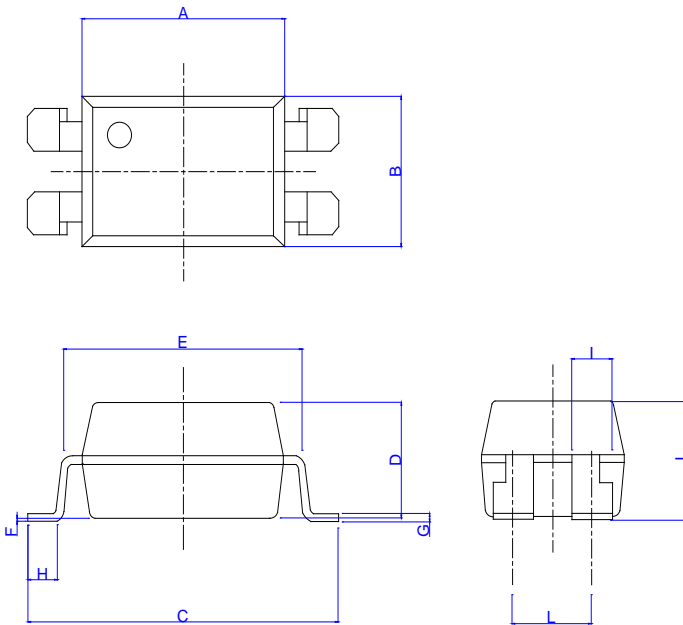

Ref.	Dimensions					
	Millimeters			Inches		
	Min.	Typ.	Max.	Min.	Typ.	Max.
A	6.00		7.00	0.236		0.276
B	4.08		5.08	0.161		0.200
C	9.50		10.50	0.374		0.413
D	3.00		4.00	0.118		0.157
E	7.32		7.92	0.288		0.312
F	0.00		0.60	0.000		0.024
G	0.15		0.36	0.006		0.014
H	0.50		1.40	0.020		0.055
I	0.90		1.50	0.035		0.059
J	3.20		4.35	0.126		0.171
L	2.29		2.79	0.090		0.110

Option SLM Type:

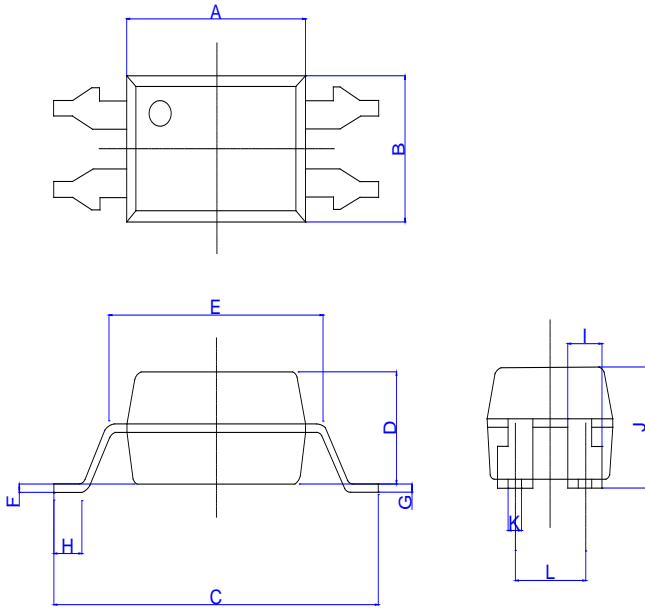

Ref.	Dimensions					
	Millimeters			Inches		
	Min.	Typ.	Max.	Min.	Typ.	Max.
A	6.30		6.70	0.248		0.264
B	4.38		4.78	0.172		0.188
C	11.60		12.10	0.457		0.476
D	3.30		3.70	0.130		0.146
E	7.32		7.92	0.288		0.312
F	0.00		0.30	0.000		0.012
G	0.20		0.30	0.008		0.012
H	0.50		0.90	0.020		0.035
I	1.15		1.35	0.045		0.053
J	3.45		3.85	0.136		0.152
K	0.45		0.55	0.018		0.022
L	2.34		2.74	0.092		0.108

**RECOMMENDED SOLDER MASK (Dimensions in mm unless otherwise stated)**

Option S

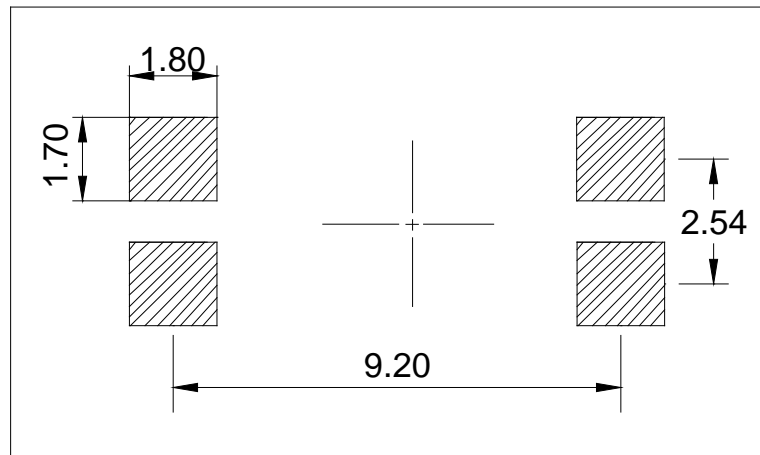

Option SL

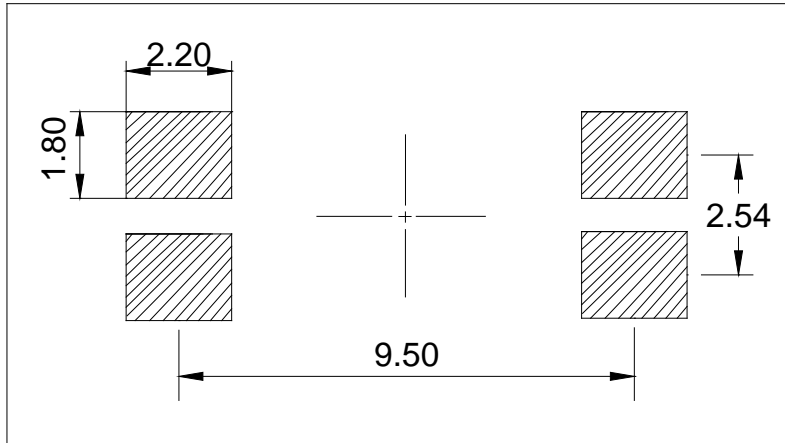

Option SLM

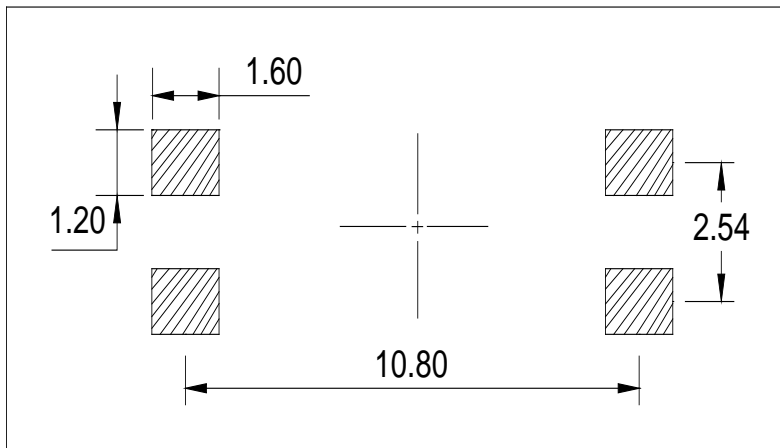

**TUBE SPECIFICATIONS (Dimensions in mm unless otherwise stated)**

**Standard DIP**

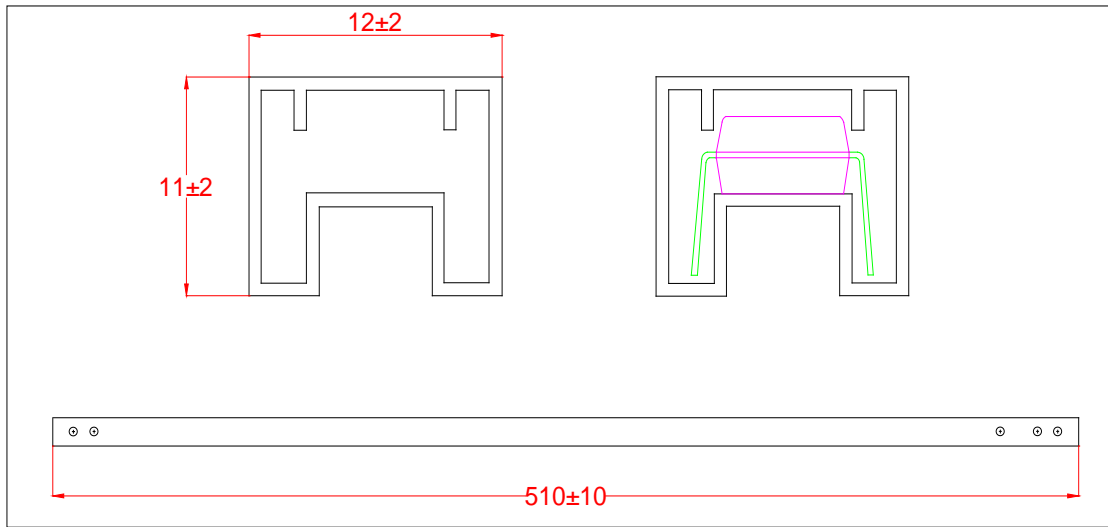

**Option M**

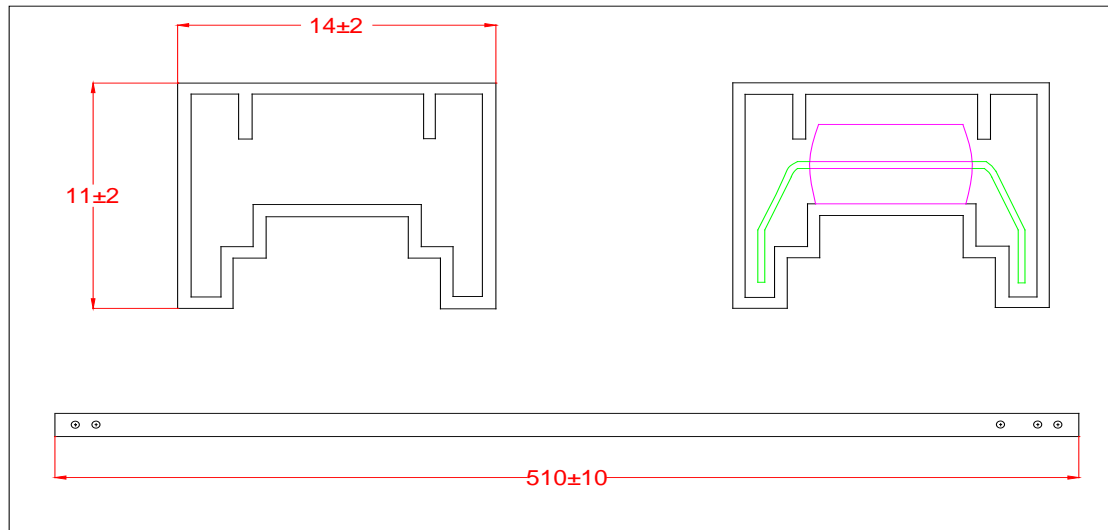

**CARRIER TAPE SPECIFICATIONS (Dimensions in mm unless otherwise stated)**

**Option S(T1)**

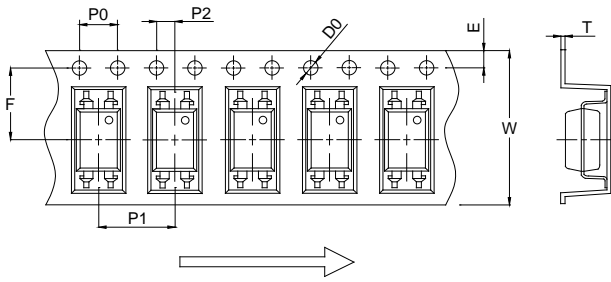

**Option S(T2)**

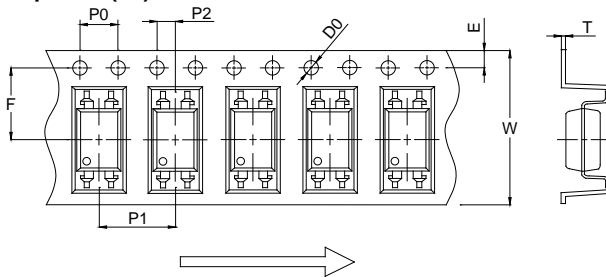

Ref.	Dimensions					
	Millimeters			Inches		
	Min.	Typ.	Max.	Min.	Typ.	Max.
D0		1.50	1.65		0.059	0.065
P0	3.90	4.00	4.10	0.154	0.157	0.161
P1	7.90	8.00	8.10	0.311	0.315	0.319
P2	1.90	2.00	2.10	0.075	0.079	0.083
E	1.65	1.75	1.85	0.065	0.069	0.073
F	7.40	7.50	7.60	0.291	0.295	0.299
T	0.30	0.40	0.50	0.012	0.016	0.020
W	15.70	16.00	16.30	0.618	0.630	0.642

**Option S(T3)**

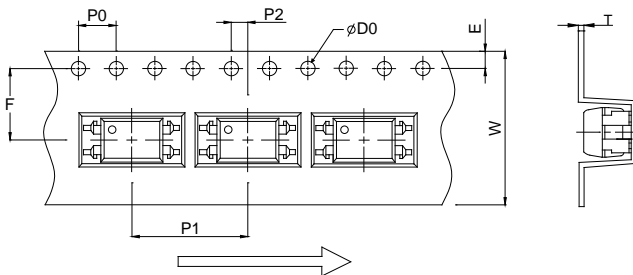

**Option S(T4)**

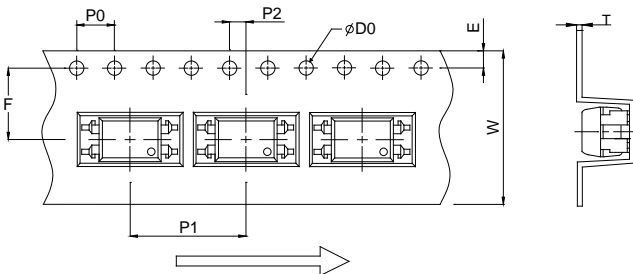

Ref.	Dimensions					
	Millimeters			Inches		
	Min.	Typ.	Max.	Min.	Typ.	Max.
D0		1.50	1.65		0.059	0.065
P0	3.90	4.00	4.10	0.154	0.157	0.161
P1	11.90	12.00	12.10	0.469	0.472	0.476
P2	1.90	2.00	2.10	0.075	0.079	0.083
E	1.65	1.75	1.85	0.065	0.069	0.073
F	7.40	7.50	7.60	0.291	0.295	0.299
T	0.30	0.40	0.50	0.012	0.016	0.020
W	15.70	16.00	16.30	0.618	0.630	0.642

**Option SL(T1)**

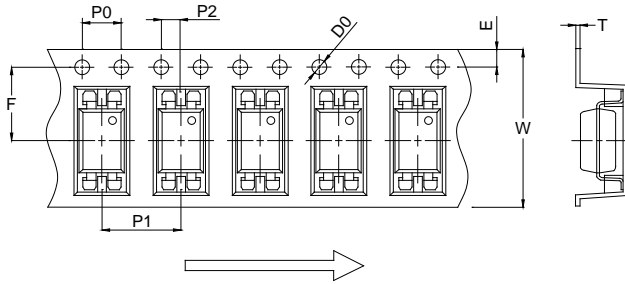

Ref.	Dimensions					
	Millimeters			Inches		
	Min.	Typ.	Max.	Min.	Typ.	Max.
D0		1.50	1.60		0.059	0.065
P0	3.90	4.00	4.10	0.154	0.157	0.161
P1	7.90	8.00	8.10	0.311	0.315	0.319
P2	1.90	2.00	2.10	0.075	0.079	0.083
E	1.65	1.75	1.85	0.065	0.069	0.073
F	7.40	7.50	7.60	0.291	0.295	0.299
T	0.35	0.40	0.45	0.014	0.016	0.018
W	15.70	16.00	16.30	0.618	0.630	0.642

**Option SL(T2)**

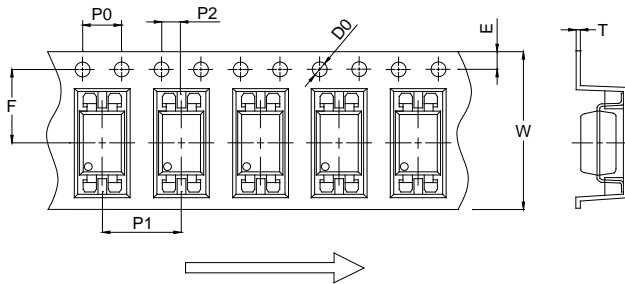

**Option SL(T3)**

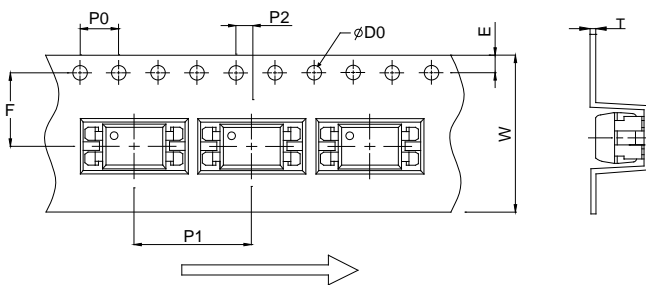

Ref.	Dimensions					
	Millimeters			Inches		
	Min.	Typ.	Max.	Min.	Typ.	Max.
D0		1.50	1.60		0.059	0.063
P0	3.90	4.00	4.10	0.154	0.157	0.161
P1	11.90	12.00	12.10	0.469	0.472	0.476
P2	1.90	2.00	2.10	0.075	0.079	0.083
E	1.65	1.75	1.85	0.065	0.069	0.073
F	7.40	7.50	7.60	0.291	0.295	0.299
T	0.35	0.45	0.55	0.014	0.018	0.022
W	15.70	16.00	16.30	0.618	0.630	0.642

**Option SL(T4)**

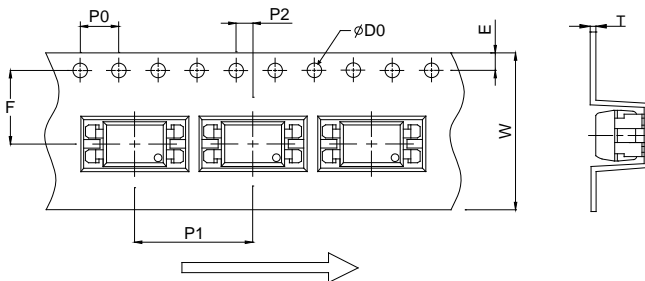

Option SLM(T1)

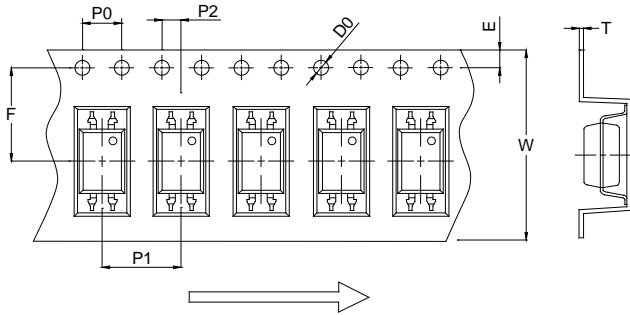

Option SLM(T2)

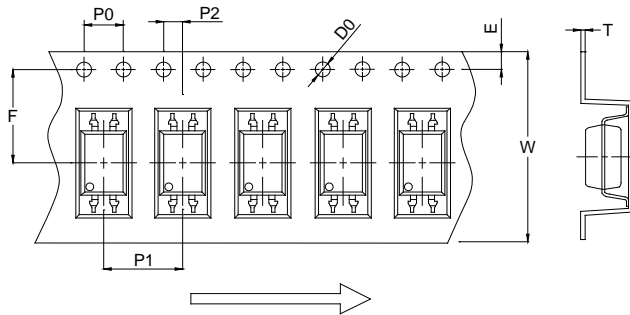

Ref.	Dimensions					
	Millimeters			Inches		
	Min.	Typ.	Max.	Min.	Typ.	Max.
D0		1.50	1.60		0.059	0.063
P0	3.90	4.00	4.10	0.154	0.157	0.161
P1	7.90	8.00	8.10	0.311	0.315	0.319
P2	1.90	2.00	2.10	0.075	0.079	0.083
E	1.65	1.75	1.85	0.065	0.069	0.073
F	11.45	11.50	11.55	0.451	0.453	0.455
T	0.35	0.40	0.55	0.014	0.016	0.022
W	23.70	24.00	24.30	0.933	0.945	0.957

REFLOW INFORMATION

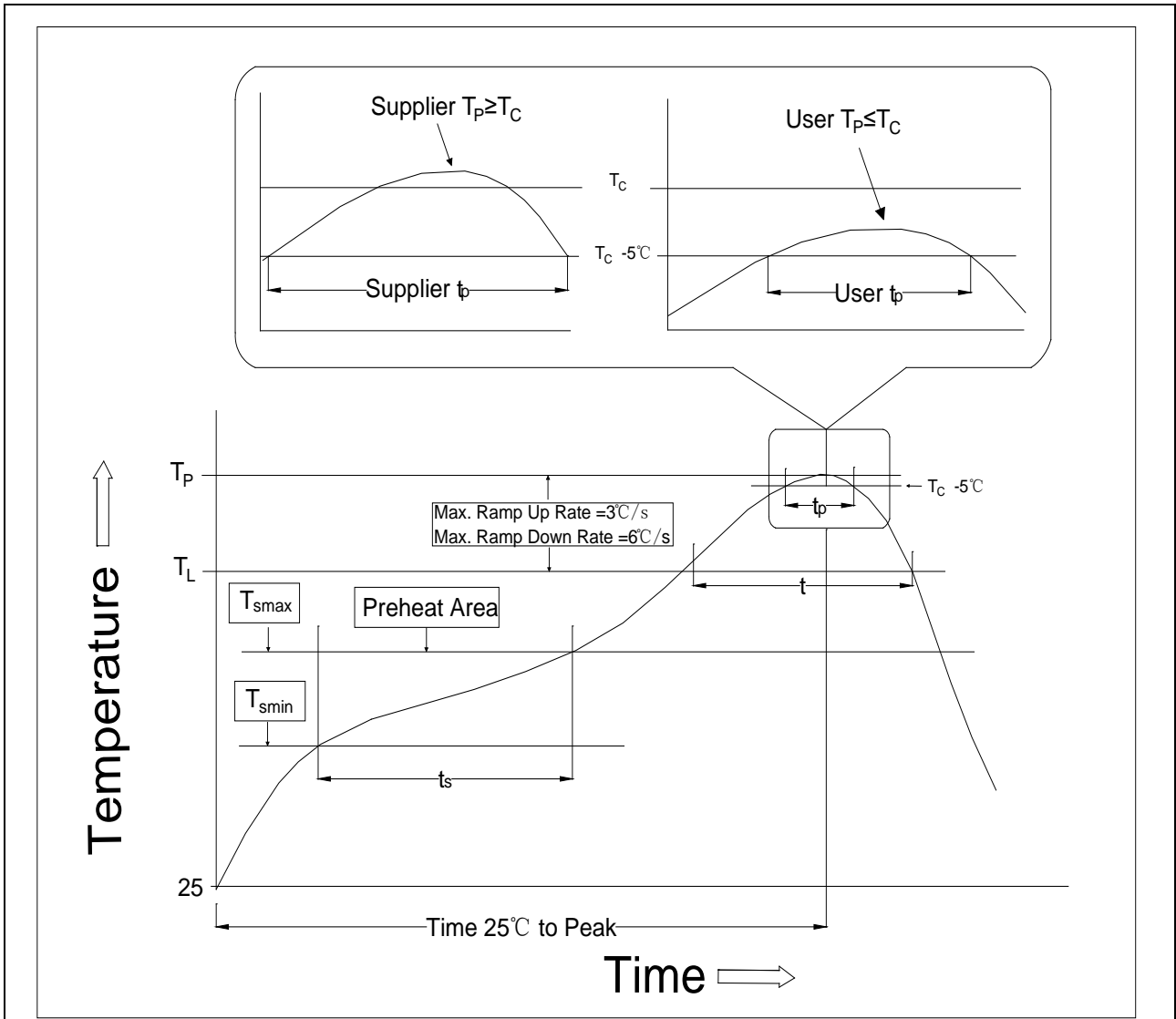

Profile Feature	Sn-Pb Assembly Profile	Pb-Free Assembly Profile
Temperature Min. (T <sub>smin</sub> )	100	150°C
Temperature Max. (T <sub>smax</sub> )	150	200°C
Time (t <sub>s</sub> ) from (T <sub>smin</sub> to T <sub>smax</sub> )	60-120 seconds	60-120 seconds
Ramp-up Rate (t <sub>L</sub> to t <sub>P</sub> )	3°C/second max.	3°C/second max.
Liquidus Temperature (T <sub>L</sub> )	183°C	217°C
Time (t <sub>L</sub> ) Maintained Above (T <sub>L</sub> )	60-150 seconds	60-150 seconds
Peak Body Package Temperature	235°C+0°C/-5°C	260°C+0°C/-5°C
Time (t <sub>P</sub> ) within 5°C of 260°C	20 seconds	30 seconds
Ramp-down Rate (T <sub>P</sub> to T <sub>L</sub> )	6°C/second max.	6°C/second max.
Time 25°C to Peak Temperature	6 minutes max.	8 minutes max.

**WAVE SOLDERING**

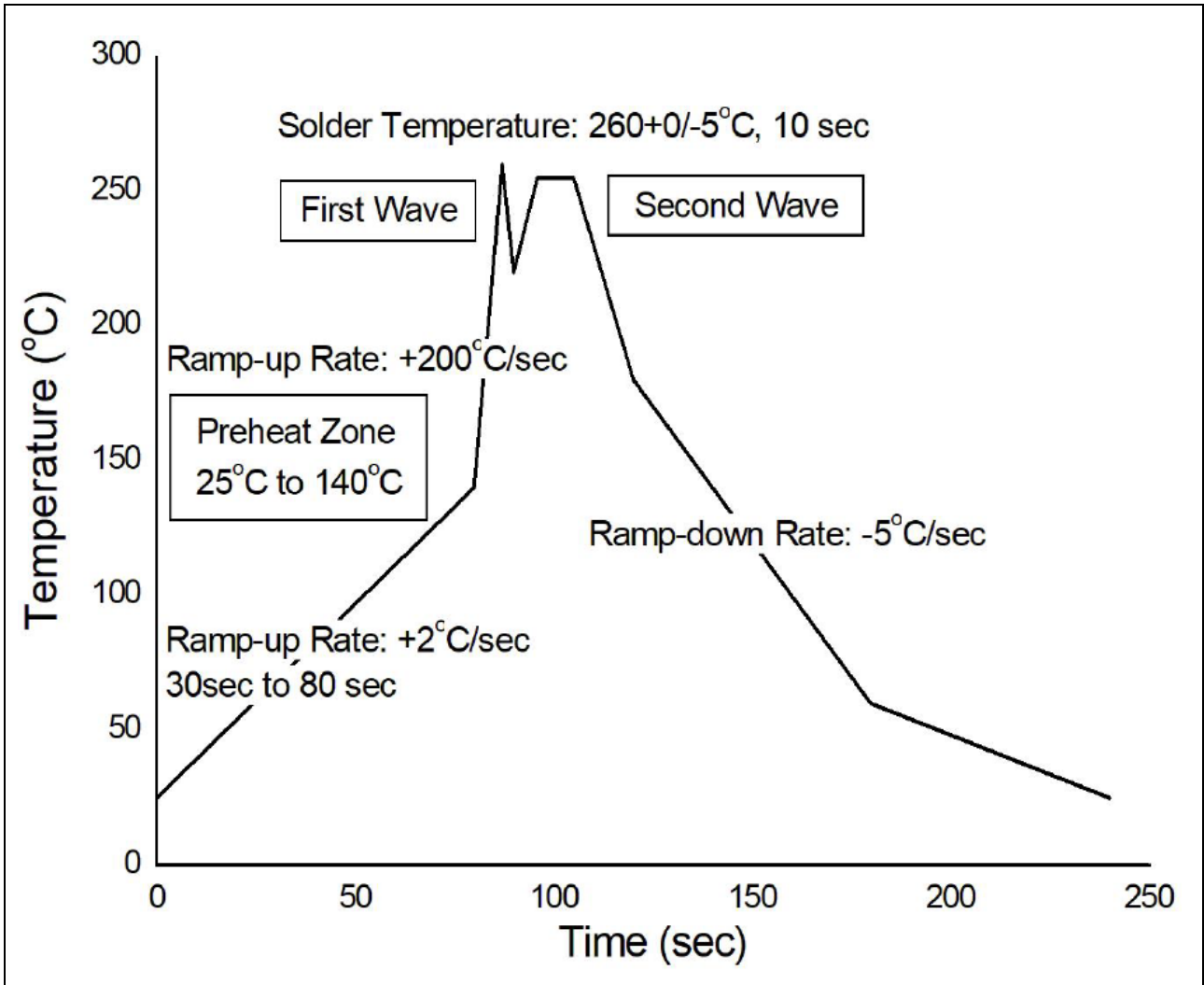

**HAND SOLDERING BY SOLDERING IRON**

Soldering Temperature	360±5°C
Soldering Time	3s max.

Information furnished in this document is believed to be accurate and reliable. However, Jiangsu JieJie Microelectronics Co., Ltd. assumes no responsibility for the consequences of use without consideration for such information nor use beyond it. Information mentioned in this document is subject to change without notice, apart from that when an agreement is signed, Jiangsu JieJie complies with the agreement.

Products and information provided in this document have no infringement of patents. Jiangsu JieJie assumes no responsibility for any infringement of other rights of third parties which may result from the use of such products and information. This document supersedes and replaces all information previously supplied.

 is a registered trademark of Jiangsu JieJie Microelectronics Co., Ltd.

Copyright © 2025 Jiangsu JieJie Microelectronics Co., Ltd. All rights reserved.