

JOR258HD6 Series

DIP6, 1 Form A 1500V High Sensitivity PhotoMOS Relay

Description

The JOR258HD6 photorelay consists of infrared light-emitting diode, photoelectric generator, and optical MOSFET coupling.

Features

- Load voltage: 1,500 V
- Load current: 20 mA
- Distance between output terminals are longer than 6-pin DIP package

Applications

- Isolation detection
- Voltage monitoring
- Signal control

SCHEMATIC

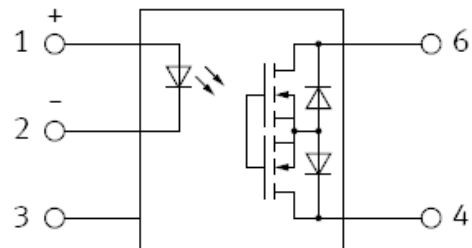

PIN DEFINITION

1. Anode	6. Drain
2. Cathode	5. NC
3. NC	4. Drain

PACKAGE

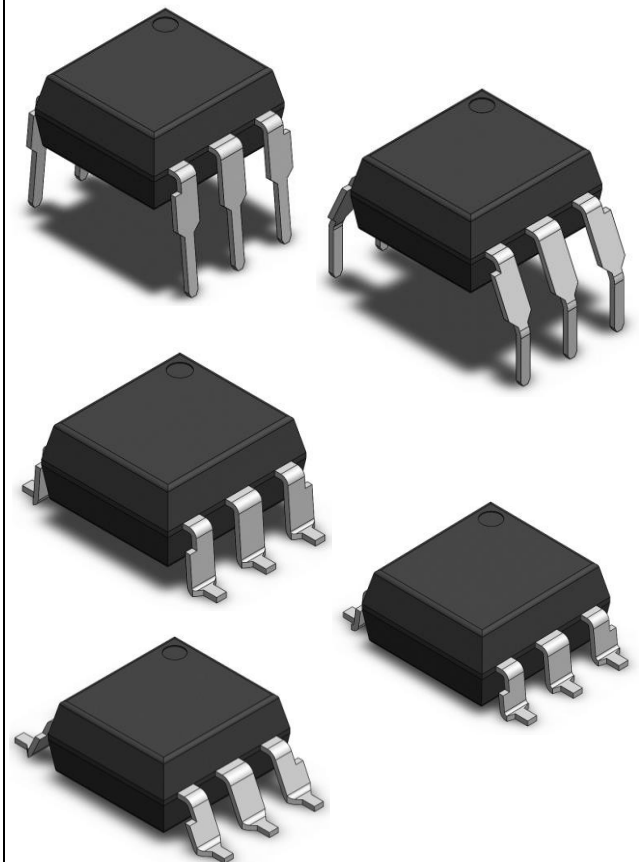

ABSOLUTE MAXIMUM RATINGS				
PARAMETER		SYMBOL	Rating	UNIT
Input	Forward Current	I _F	20	mA
	Reverse Voltage	V _R	6	V
	Junction Temperature	T _J	125	°C
	Power Dissipation	P	50	mW
Output	Load voltage (peak AC)	V _L	1500	V
	Continuous load current	I _L	20	mA
	Peak load current	I _{peak}	60	mA
	Junction Temperature	T _J	125	°C
	Output Power Dissipation	P _o	360	mW
Total Power Dissipation		P _{tot}	400	mW
Isolation Voltage (Note 1)		V _{iso}	5000	V _{rms}
Operating Temperature		T _{opr}	-40~+110	°C
Storage Temperature		T _{sig}	-55~+150	°C
Soldering Temperature (Note 2)		T _{sol}	260	°C

Note: Ambient temperature = 25°C, unless otherwise specified. Stresses exceeding the absolute maximum ratings can cause permanent damage to the device. Exposure to absolute maximum ratings for long periods of time can adversely affect reliability.

Note 1: AC For 1 Minute, R.H. = 40 ~ 60%

Isolation voltage shall be measured using the following method.

- (1) Short between anode and cathode on the primary side and between collector and emitter on the secondary side.
- (2) The isolation voltage tester with zero-cross circuit shall be used.
- (3) The waveform of applied voltage shall be a sine wave.

Note 2: For 10 Seconds

RECOMMENDED OPERATION CONDITIONS					
CHARACTERISTICS		SYMBOL	MIN.	MAX.	UNIT
LED Forward Current		I _F	1	5	mA
JOR258HD6	Load voltage (Peak AC)	V _L	-	1200	V
	Continuous load current	I _L	-	20	mA

Note: Recommended operating conditions are given as a design guideline to obtain expected performance of the device. Additionally, each item is an independent guideline respectively. In developing designs using this product, please confirm specified characteristics shown in this document.

ELECTRICAL OPTICAL CHARACTERISTICS						
PARAMETER	SYMBOL	MIN.	TYP.	MAX.	UNIT	TEST CONDITION
INPUT CHARACTERISTICS						
Forward Voltage	V_F	-	1.8	2.2	V	$I_F = 1 \text{ mA}$
Reverse Current	I_R	-	0.05	10	μA	$V_R = 5\text{V}$
OUTPUT CHARACTERISTICS						
Off state leakage current	I_{Leak}	-	0.1	10	μA	$I_F = 0\text{mA}$ $V_L = \text{Max}$
On resistance	R_{ON}	-	270	500	Ω	$I_F = 1\text{mA}$ $I_L = \text{Max}$
COUPLE CHARACTERISTICS						
LED operate current	I_{FON}	-	0.1	1	mA	$I_L = 20\text{mA}$
LED turn off voltage	V_{FOFF}	0.8	1.7		V	$I_L \leq 10 \mu\text{A}$
Turn on time	T_{ON}	-	0.2	1	ms	$I_F = 1\text{mA}$ $I_L = \text{Max}$
Turn off time	T_{OFF}		0.1	0.2	ms	$I_F = 1\text{mA}$ $I_L = \text{Max}$

PACKAGE DIMENSIONS (Dimensions in mm unless otherwise stated)

Through hole package Lead Forming

DIP type Dimension

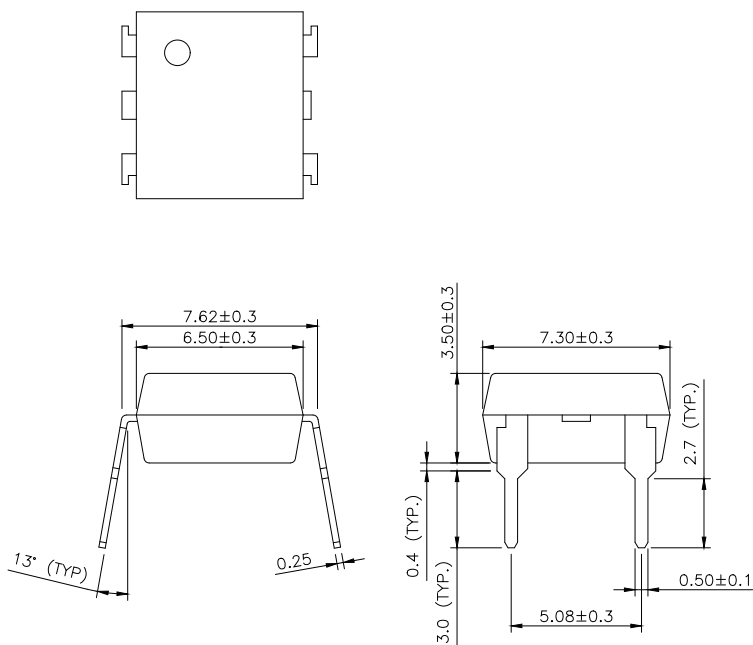

M type Dimension

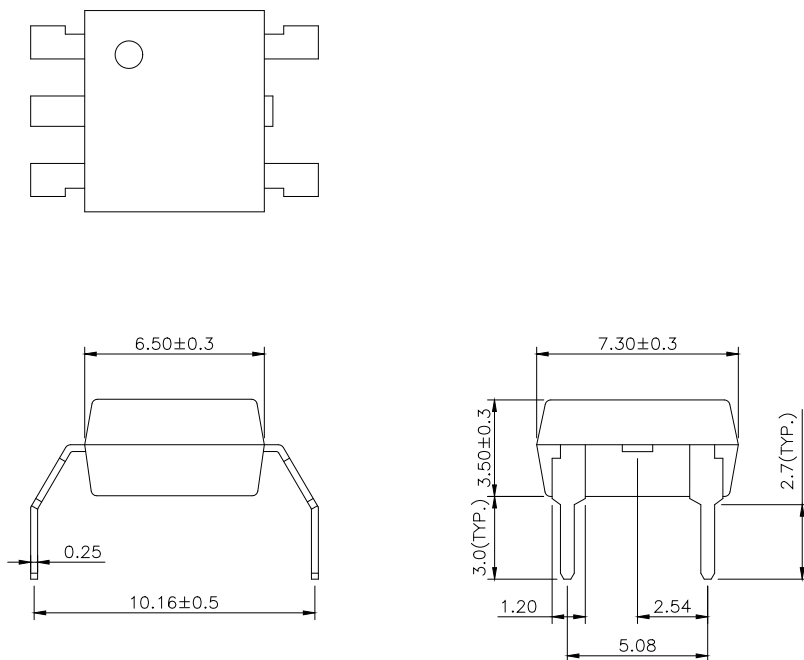

PACKAGE DIMENSIONS (Dimensions in mm unless otherwise stated)

Surface Mount Lead Forming

SL type Dimension

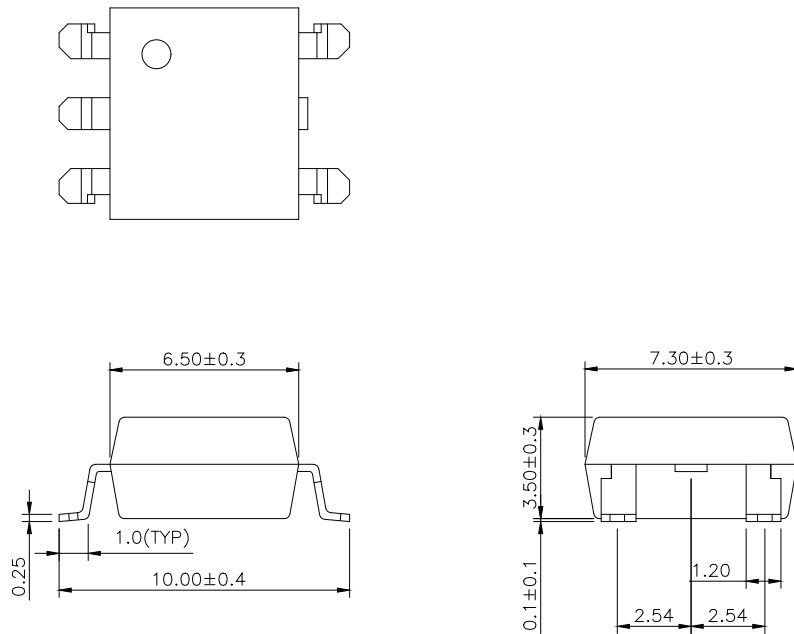

SLM type Dimension

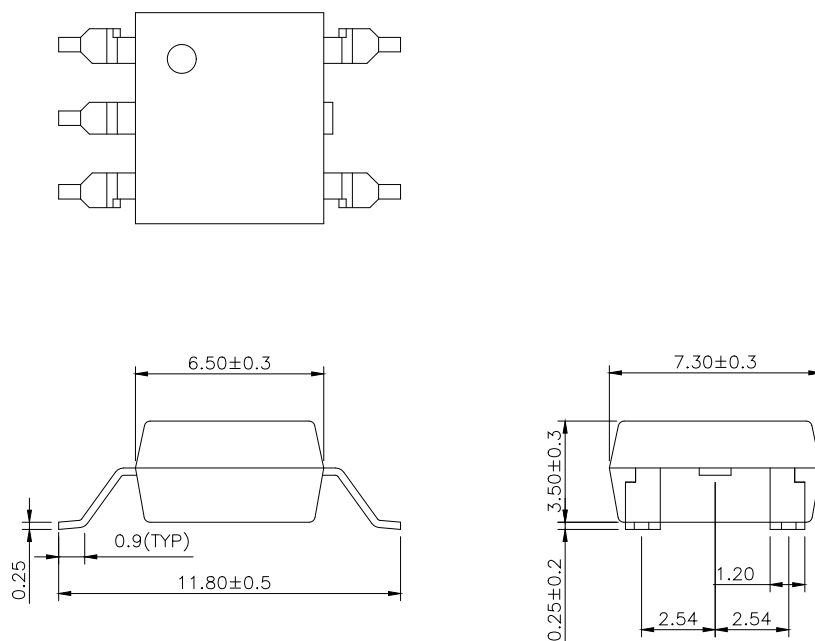

TAPING DIMENSIONS (Dimensions in mm unless otherwise stated)

SL type Taping Dimensions

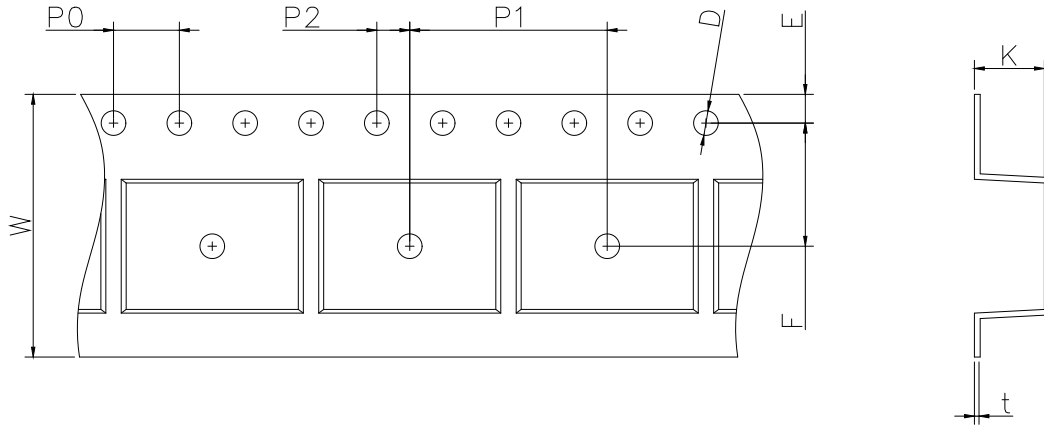

Dimension Symbol	D	E	F	P0	P1	P2	t	W	K
Dimension (mm)	1.55±0.2	1.75±0.2	7.5±0.2	4.0±0.2	12.0±0.2	2.0±0.2	0.35±0.2	16.0±0.3	4.25±0.2

Tape & Reel Packing Specifications

Option T1

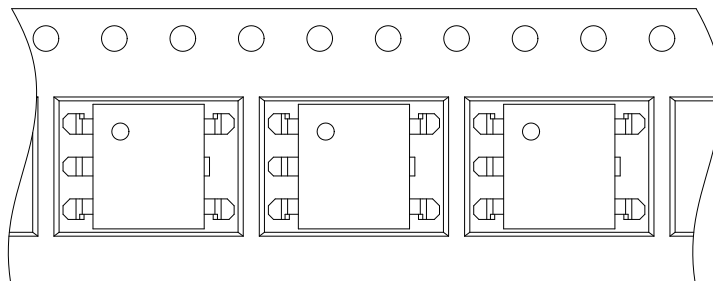

Option T2

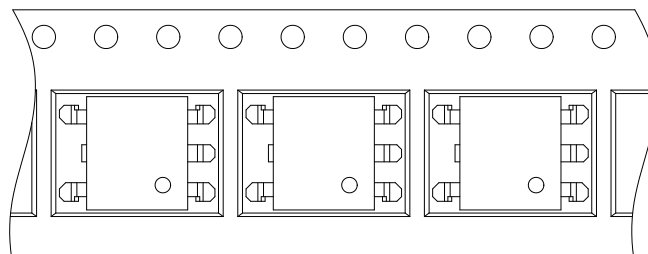

TAPING DIMENSIONS (Dimensions in mm unless otherwise stated)

SLM type Taping Dimensions

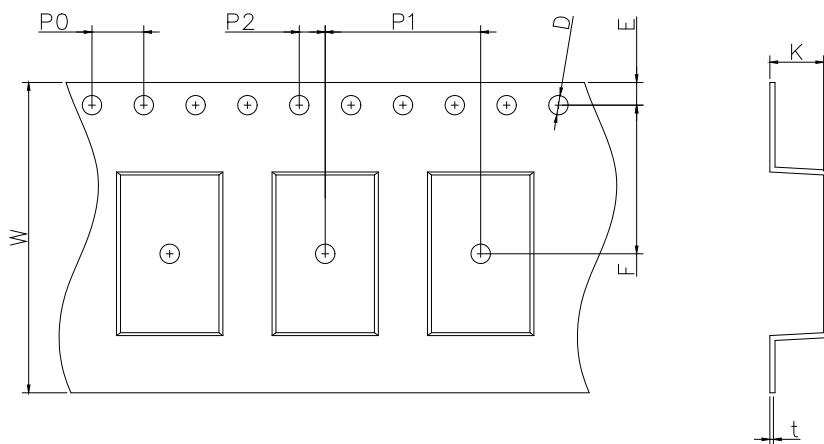

Dimension Symbol	D	E	F	P0	P1	P2	t	W	K
Dimension (mm)	1.5±0.2	1.75±0.2	11.5±0.2	4.0±0.2	12.0±0.2	2.0±0.2	0.4±0.2	24.0±0.3	4.15±0.2

Tape & Reel Packing Specifications

Option T1

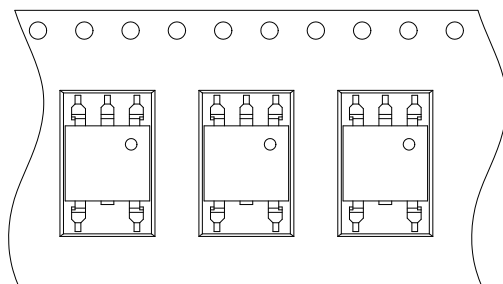

Option T2

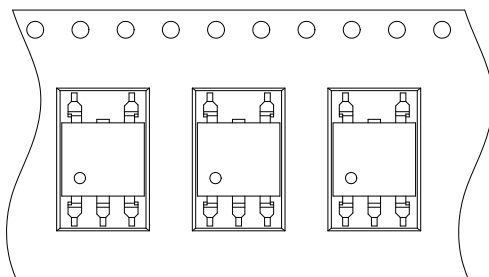

MARKING INFORMATION

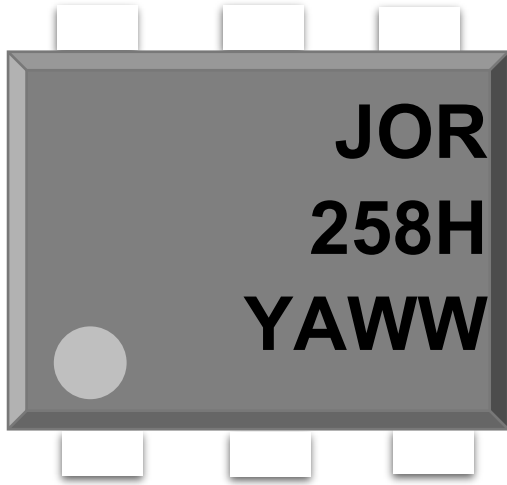

JOR : Company Abbr.
 258H : Part Number
 YAWW : LOT NO.

ORDERING INFORMATION

LABEL INFORMATION

JOR258HDX(Y)(Z)-G

JOR – Company Abbr
 258H – Part Number
 D – DIP or SMD Package
 X – 6(Pin Count)
 Y – Lead Form Option (SL/None)
 Z – Tape and Reel Option (T1/T2)
 G – Green

 捷捷微电（深圳）有限公司
 JIEJIE MICROELECTRONICS (Shenzhen) Co Ltd

Part No.:XXXXXXXXX Bin Code: X



Lot No.: XXXXXXXXXXXX

Date Code: XXXX

QTY: XXX PCS



Precautions for Soldering

IR Reflow soldering

One time soldering reflow is recommended within the condition of temperature and time profile shown below. Do not solder more than three times.

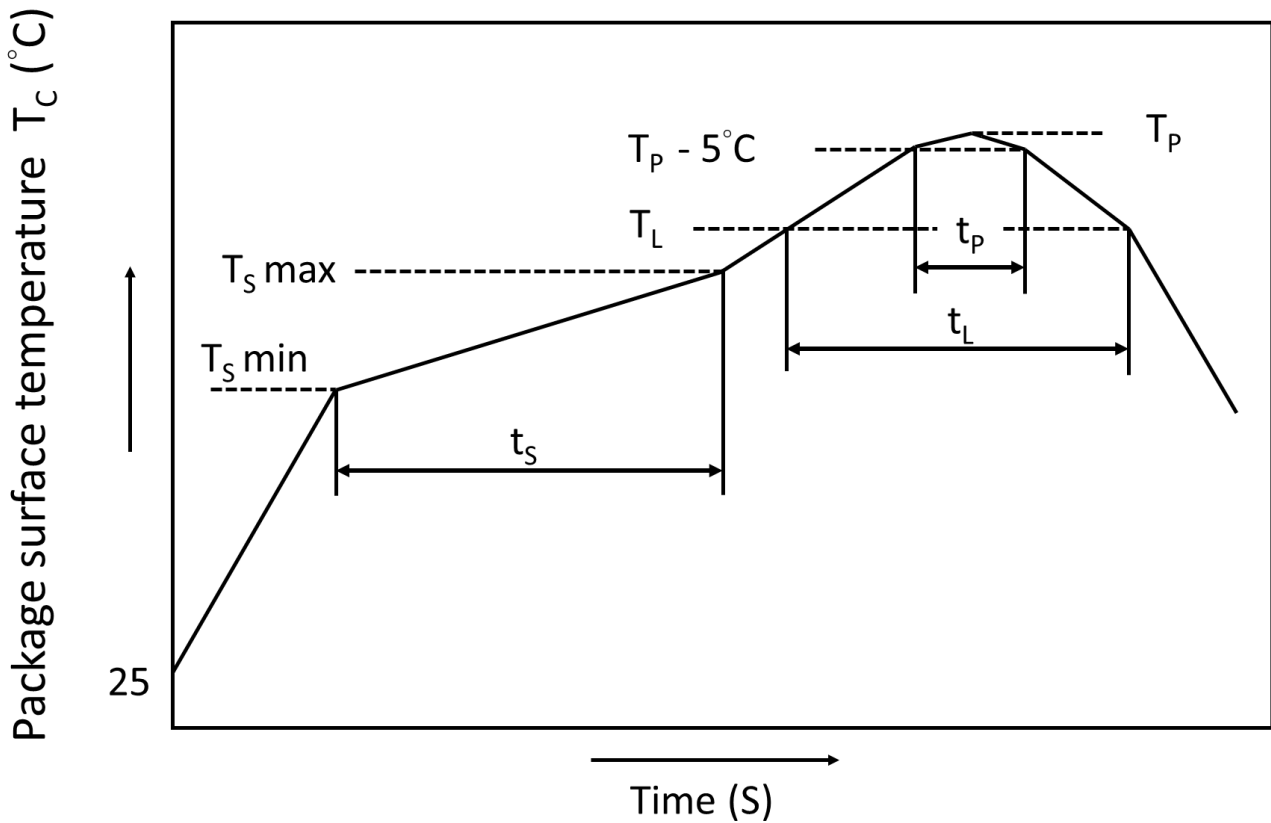

	Symbol	Min	Max	Unit
Preheat temperature	T_s	150	200	°C
Preheat time	t_s	60	120	s
Ramp-up rate (T_L to T_P)			3	°C/s
Liquidus temperature	T_L	217		°C
Time above T_L	t_L	60	100	s
Peak Temperature	T_P		260	°C
Time during which T_C is between ($T_P - 5$) and T_P	t_P		20	s
Ramp-down rate			6	°C/s

DISCLAIMER

- Our company is continually improving the quality, reliability, function and design. Our company reserves the right to make changes without further notices.
- The characteristic curves shown in this datasheet are representing typical performance which are not guaranteed.
- Our company makes no warranty, representation or guarantee regarding the suitability of the products for any particular purpose or the continuing production of any product. To the maximum extent permitted by applicable law, Our company disclaims (a) any and all liability arising out of the application or use of any product, (b) any and all liability, including without limitation special, consequential or incidental damages, and (c) any and all implied warranties, including warranties of fitness for particular
- The products shown in this publication are designed for the general use in electronic applications such as office automation, equipment, communications devices, audio/visual equipment, electrical application and instrumentation purpose, non-infringement and merchantability.
- This product is not intended to be used for military, aircraft, medical, life sustaining or lifesaving applications or any other application which can result in human injury or death.
- Please contact Our company sales agent for special application request.
- Immerge unit's body in solder paste is not recommended.
- Parameters provided in datasheets may vary in different applications and performance may vary over time. All operating parameters, including typical parameters, must be validated in each customer application by the customer's technical experts. Product specifications do not expand or otherwise modify Our company's terms and conditions of purchase, including but not limited to the warranty expressed therein.
- Discoloration might be occurred on the package surface after soldering, reflow or long-time use. It neither impacts the performance nor reliability.